

# Curriculum Vitae: Dr Jasper L. Coetzee

---



## Education and qualifications

1999-2001    PhD “An optimised instrument for designing a maintenance plan—A sequel to Reliability Centred Maintenance”

University of Pretoria

Supervised by prof Schalk Claasen

Synopsis of thesis:

Reliability Centred Maintenance (RCM) started a new chapter in the history of preventive maintenance strategy setting. It was now possible to develop a scientifically based, highly successful maintenance program for complex systems. It developed as a result of the reliability problems and cost of maintenance of aircraft during the late 50's and early 60's. The result was a methodology called MSG-1, followed by the improved MSG-2. When MSG-2 was used contractually for the United States Department of Defence, it led to the present definition of RCM.

In academic circles there developed a growing dissatisfaction with the technique, of which part stems from watering down its scientific basis to make RCM more marketable, while at least part is based on perceived inherent scientific weaknesses in the methodology itself.

The thesis, in setting out to solve these limitations, makes several important contributions to the RCM methodology. The first of these is a method of concentrating the RCM analysis effort on the most important failure modes encountered by the organisation. Secondly, it introduces a Quality Improvement task in the RCM task selection tree. The third contribution is the addition of a formal task packaging methodology. The thesis also combines the use of RCM for the most important failure modes with conventional maintenance tasks for the remaining failure modes, to form a total methodology for the typical industrial concern. It furthermore introduces the application of sound management principles in the implementation of RCM and lastly, blends concepts from different RCM authors, together with the innovations listed above, into one logical whole.

---

1994-1995    M Eng (Industrial) “Die analise van falingsdata met ‘n langtermintendens”  
- Cum Laude

University of Pretoria

Study Leader: Prof Schalk Claasen

Co-leader: Dr Marietjie Vosloo

Synopsis of dissertation

The analysis of failure data is an important facet in the development of maintenance strategy for equipment. Only by properly understanding the mechanism of failure, through the modelling of failure data, can a proper

maintenance plan be developed. This is normally done by means of probabilistic analysis of the failure data. From this conclusions can be reached regarding the effectiveness and efficiency of preventive replacement (and overhaul) as well as that of predictive maintenance. The optimal frequency of maintenance can also be established by using well developed optimisation models, which optimises outputs such as profit, cost and availability. The problem with this approach is that it assumes that all repairable systems are repaired to the "good-as-new" condition at each repair occasion. Maintenance practise has learnt, however, that in many cases equipment slowly degrades even while being properly maintained (including part replacement and periodic overhaul). The result of this is that failure data sets often display degradation. This renders conventional probabilistic analysis useless. During the last two decades a few researchers applied themselves to the solution of this problem.

The dissertation examines the present state of the theoretical foundation of repairable systems analysis techniques with a view to find a practical way for the maintenance analyst. After thorough study the Non Homogeneous Poisson Process model (NHPP model) is chosen as a model for which the theory are well developed, of which the mathematical manipulations are tractable and have been tested well. The model is fully developed in the dissertation, including an identification framework, goodness-of-fit tests, confidence intervals and optimisation modelling. The model is tested on two failure data sets from literature and one from industry. The results are successful and the dissertation reaches it's goal of documenting a practical and useful analysis technique for the analysis of failure data with a trend.

---

1980-1981	<b>B.Eng.(Industrial) (Hons)</b>  University of Pretoria  Subjects: Reliability Operational Research Logistics Work and Method study
1980	<b>Registration as Professional Engineer</b>
1975-1979	<b>B.Com</b>  Unisa (University of South Africa)  Major Subjects: Accounting Economics Business Economics Computer Science
1975	<b>Certificate of Competency (Mechanical) (Mines)</b>
1974	<b>Certificate of Competency (Mechanical) (Factories)</b>
1968-1972	<b>B.Sc.(Eng)(Mechanical), Cum Laude</b>  University of Pretoria

---

## Curriculum Vitae: Dr Jasper L. Coetzee

**1967 - 1969 Millwright (Electromechanical)**

**Iscor, Pretoria**

---

**1967 NTS 3 - First Class**

**Pretoria Technical College**

**Subjects: Electrotechnics III - Distinction  
Applied Mechanics II - Distinction  
Mathematics III - Distinction  
Electrical Construction and Drawing**

---

**1954 - 1965 Matric - First Class**

**Langenhoven High School / Bergsig Primary School**

**Subjects: Afrikaans  
English  
Mathematics  
Science  
Accounting  
Commerce**

---



## Experience

- 1967-1969** Enrolled as apprentice millwright (electromechanical) at Iscor, Pretoria. Studies part time in Engineering at the Technical College, Pretoria (now Tswane University of Technology) and the University of Pretoria.
- 
- 1970-1972** Studies in mechanical engineering at the University of Pretoria. Member of the Pretoria University choir.
- 
- 1973** Starts working as Senior Researcher at Iscor Headquarters, Pretoria. Does various smaller investigations. Member of a team that investigates and solves a design problem causing the sides of sheet metal produced in the Vanderbijlpark works to be severely deformed. Establishes the values of roof design parameters for Iscor's Deltarib corrugated roof covering material for publication in a design guide.
- 
- 1974** Works as engineer in training at Iscor's Thabazimbi iron ore mine. Responsible for various design investigations to establish the viability of projects and to improve problem systems. Also gains experience as first line supervisor.
- 
- 1975-1979** Appointed as Assistant Resident Engineer with full statutory responsibility for a part of the mine. During this period manages various parts of the mine's engineering department, including the design office, various construction projects (including the installation of a large underground crusher plant), capital purchases for the whole mine, service workshops as well as the maintenance of the ore beneficiation plant, underground mining equipment, open cast mining equipment and all infrastructure.
- 
- 1980-1982** Appointed at Sasol's Sigma Colliery as Resident Engineer. Carries full statutory responsibility for all machinery and is also responsible for the execution of all capital projects, all engineering design work, the operation of all coal transport systems and the surface crushing and screening plant as well as the maintenance of all equipment (underground, surface and infrastructure). Achievements during this period includes the building and installation of a computerised maintenance system, a decrease in maintenance costs of 10% in real terms, high average availability of equipment (80% plus) and the lowering of the engineering department's accident frequency to well below the industry average. The engineering department in this way contributed to the achievement of long wall and continuous miner world records as well as an National Productivity Institute award for productivity improvement.
-

## Curriculum Vitae: Dr Jasper L. Coetzee

**1983-1984** Appointed as Manager, Mechanical Department, Sasol One with statutory responsibility for all mechanical and civil equipment. Responsible for all mechanical and civil service workshops, infra-structure and area maintenance using in the order of 1500 people. Achievements include the establishment of a specialised mechanical services division, the initiation of a study into the adequacy of the factory's maintenance facilities as well as a pilot study in the analysis of plant historical data to achieve an improvement in plant availability, the improvement of the department's team cohesion using organisation development techniques and the improvement of budget/ cost control discipline.

---

**1985-1986** Seconded to Group Information Services, Sasol One as Manager, Maintenance Project with the instruction to establish a maintenance management information system for the Sasol Group of Companies. Controls a team of 20 specialists, who did a full systems analysis with a Functional Specification Report for a custom made system as end result. Due to a change in company priorities this was followed by a complete package survey and selection.

---

**1987-1993** Director of M-Tech Consulting Engineers (Pty) Ltd, a company that does mechanical and industrial engineering consultation. Work done during this period includes:

---

- The installation of a computerised maintenance information system at a major colliery. This work included the following functional areas:
    - ⇒ procurement of spares
    - ⇒ condition monitoring
    - ⇒ maintenance documentation
    - ⇒ fault diagnosis
    - ⇒ maintenance supervision
    - ⇒ backlog management
    - ⇒ artisan time utilisation
    - ⇒ maintenance facilities
    - ⇒ fault cause removal
    - ⇒ reliability centred maintenance analysis
    - ⇒ workorder definition
    - ⇒ managing sub unit lives
    - ⇒ guarantee handling

---

  - A project definition phase design of a Maintenance Information System for a large industrial complex. This included the following deliverables:
    - ⇒ summary of business objectives
    - ⇒ summary of business functions
    - ⇒ summary of information needs
    - ⇒ conceptual design
-

- ⇒ **project data model**
  - ⇒ **interface memorandum**
  - ⇒ **risk memorandum**
  - ⇒ **installation work plan**
- 

- **The design, project management and installation of a computerised production monitoring system at a large wire mill. This included the procurement of all hardware, the design and writing of all software and the final installation and testing of the system. The system supplies vital management information on a daily basis. This system was a pilot scale design study to investigate the possibility of automating the whole plant in a similar fashion.**
- 

- **A simulation study into the various options for the transport of ore on surface at a large mining complex. The complex consists of 13 mine shafts that are connected to a central ore beneficiation plant via a rail network. M-Tech was commissioned to do a simulation study to enable the management of the complex to do long term planning. Decisions that had to be taken during the planning process included shaft and additional plant location decisions as well as rail network design. The simulation work was done in a commercially available simulation language SLAM.**
- 

- **The development of a custom built simulation system to handle the abovementioned problem. The system is fully commercialised and can handle any similar simulation problem. The simulation process is handled using 13 multifaceted matrices and 2 history files. Customised reports are available for each simulation run to facilitate comparisons between different rail configurations.**
- 

- **The development of a second simulation system to simulate the transport of ore in a deep underground gold mine. The mine group, for whom the system was developed, had to take decisions concerning the possibility of deeper mining activity without sinking new shafts. This has the effect of increasing the load on the transport system, which had to be investigated.**
- 

- **Two projects relating to the use of heat pumps as viable alternative for resistance and other types of heating. One of these comprises a market survey and techno-economical evaluation of heat pumps as an alternative heating method, while the other is a study of the effect of heat pumps on domestic power consumption. These projects were undertaken for the National Energy Council.**
-

1993 - Feb 2000

Senior Lecturer in Maintenance Engineering at the University of Pretoria, as well as director of M-Tech Consulting Engineers (Pty) Ltd. The teaching post was accommodated in a Chair for Maintenance Engineering and the salary was set at the maximum of an Associate Professor. Work done during this period includes:

- 
- The introduction of an undergraduate course in Maintenance Engineering.
- 
- The introduction of post graduate broadening course in Maintenance Engineering. This course is presented to practicing maintenance engineers.
- 
- The introduction of a full post graduate Masters degree specialisation in Maintenance Engineering within the Department of Mechanical and Aeronautical Engineering.
- 
- A project to increase the effectiveness of the Maintenance Information systems of a large open cast coal mine. Several successes have been achieved including establishing an integrated maintenance performance measurement process, a change from operating style management to systems driven management and a general improvement in the level of maintenance operation.
- 
- Two projects to develop maintenance policies for industrial organisations, one in open cast mining and the other one in the supply of specialised vehicles.
- 
- A life cost and failure behaviour study of the shells of three basic oxygen furnaces at a large steel manufacturer. The objective was to determine the optimum replacement life of the shell, as well as to advise on the best maintenance strategy for these units.
- 
- Regular (annual) presentation of four short courses (two days in duration each) in Maintenance Engineering:
    - ⇒ Introduction to Maintenance Engineering
    - ⇒ Quantitative Techniques in Maintenance
    - ⇒ Maintenance Performance Measurement
    - ⇒ Successful Maintenance Systems
- 
- Co-presentation of the course (3 days) “Effective Maintenance through Reliability Centred Maintenance (RCM)” (with prof. Krige Visser of Engineering Management) in March 1997.
- 
- Arrangement of three days conference “World Trends in Maintenance” with leading international academics as speakers in Maintenance Engineering in August 1997 and again in August 1999.
-



- Co-operation with prof Andrew Jardine of the University of Toronto in the presentation of his course "Maintenance Decision Making" in South Africa.

---

**Feb 2000 - Present** Managing Director of M-Tech Consulting Engineers (Pty) Ltd, a company with as main aim to play a fundamental role in improving the level of Maintenance Practice in South Africa. As such it is instrumental in formalising maintenance management theory and imparting that knowledge to Maintenance Practitioners. The drive behind this is one of helping maintenance organisations to help themselves. Following from this objective, the main activity of the organisation is Maintenance Training, with a lesser accent on Maintenance Consulting.

As from 2003 the company moved its training to the Terotechnica Maintenance College, a subsidiary organisation of M-Tech.

Specific attention is given to developing a position in the market and redeveloping and presenting a number of maintenance courses, listed with SAQA. These are presently (early 2012):

- Certificate for Artisans
- Certificate for Maintenance Supervisors
- Certificate in Maintenance Planning
- Advanced Certificate in Maintenance Planning
- Certificate in Maintenance Shutdown and Project Management
- Certificate in Reliability Engineering
- Certificate for Maintenance Engineers
- Certificate in Maintenance Management
- Certificate in RCM Facilitation and Analysis
- Reliability Centred Maintenance
- Maintenance and Reliability Principles
- Root Cause Failure Analysis
- Decision Making in Maintenance
- Maintenance Control
- Reliability Fundamentals
- Water Treatment Plant Operation and Maintenance
- Road Maintenance
- Life Cycle Cost Management

---

Specific attention was given to developing a relationship with the University of Johannesburg (RAU), which lead to an Internet based multi-modal Masters degree in Maintenance Engineering being presented under dr Coetzee's leadership from 2001 to 2011.

---

## Curriculum Vitae: Dr Jasper L. Coetzee

**Aug 2011- Present**      **Appointed as part time Associate Professor in the Centre of Excellence in Maintenance Engineering at the University of Pretoria.**

---

## Later project examples (from 2000 onwards)

### Workshop replanning project

A dynamic re-planning of a major diamond plant workshop complex facilities. The De Beers Venetia diamond mine surface plant workshops was built some 15 years ago. As time advanced, the maintenance facilities (workshops and sub-stores) were extended on an ad hoc basis on a very unplanned basis. The plant maintenance manager realised that the situation was totally unacceptable and started rationalising the organisation structure, which presently consists of in the order of 100 people, under 7 supervisors. The problem was then that, while the correct organisational structure was in place, the logistics has not been corrected in the interest of efficiency. The purpose of the study was thus to study the logistical performance of the maintenance organisation with the objective of making recommendations to improve the operational efficiency of the maintenance work. Report 46 pages.

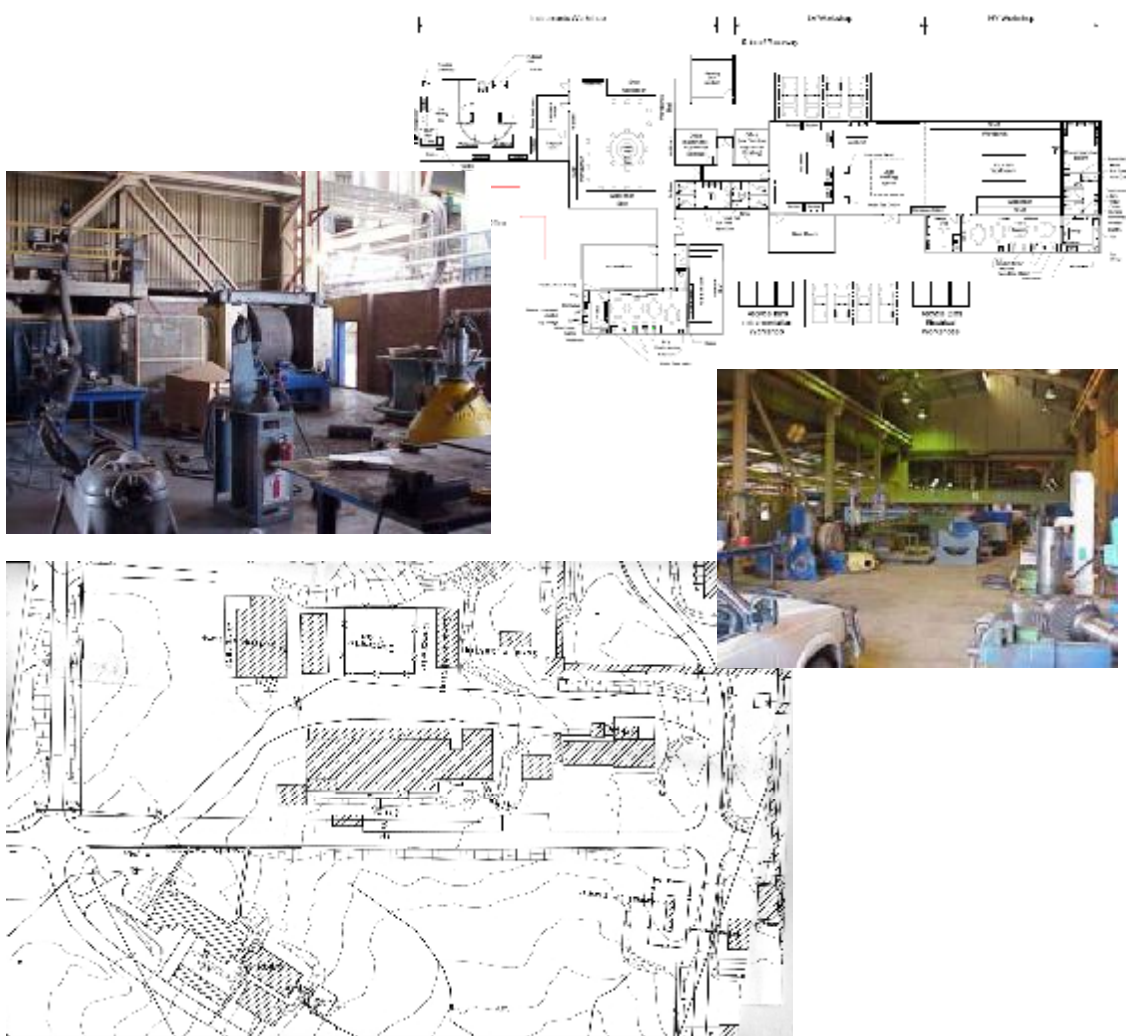

### Mine Expansion Project Supportability Analysis

Supportability analysis for the re-planning of the Andina Copper Mine in Chile. The mine was traditionally operated as a 50% underground, 50% opencast operation at a ore tonnage of 72000 tons per day. The underground workings are reaching exhaustion, and Codeco intends increasing the capacity of the mine to 92000 tons per day. The brief was to develop a maintenance strategy for a new 92000 tons per day open pit operation. Report 76 pages.

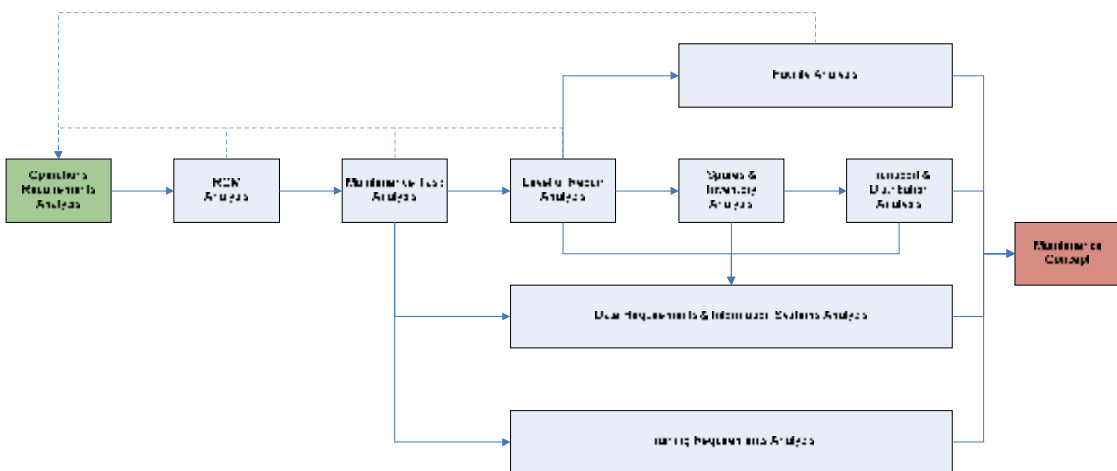
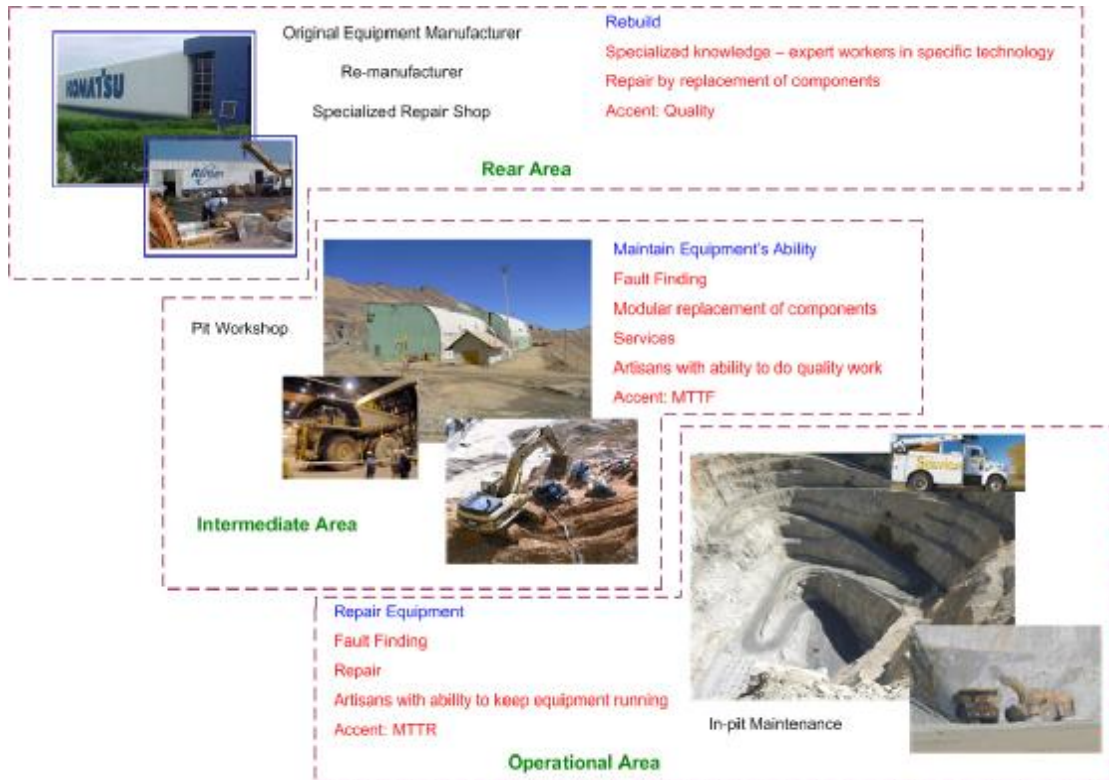

Sinter conveyor steel belt life maximisation

The life of the pellet conveying steel belt at Tubatse Ferro-chrome's new sinter plant was not acceptable and needed to be improved by implementing a properly designed maintenance strategy. A full study into the root cause of the failures was conducted, which transpired to be a Tribological problem concerning the belt/lubricant combination. Report 39 pages.

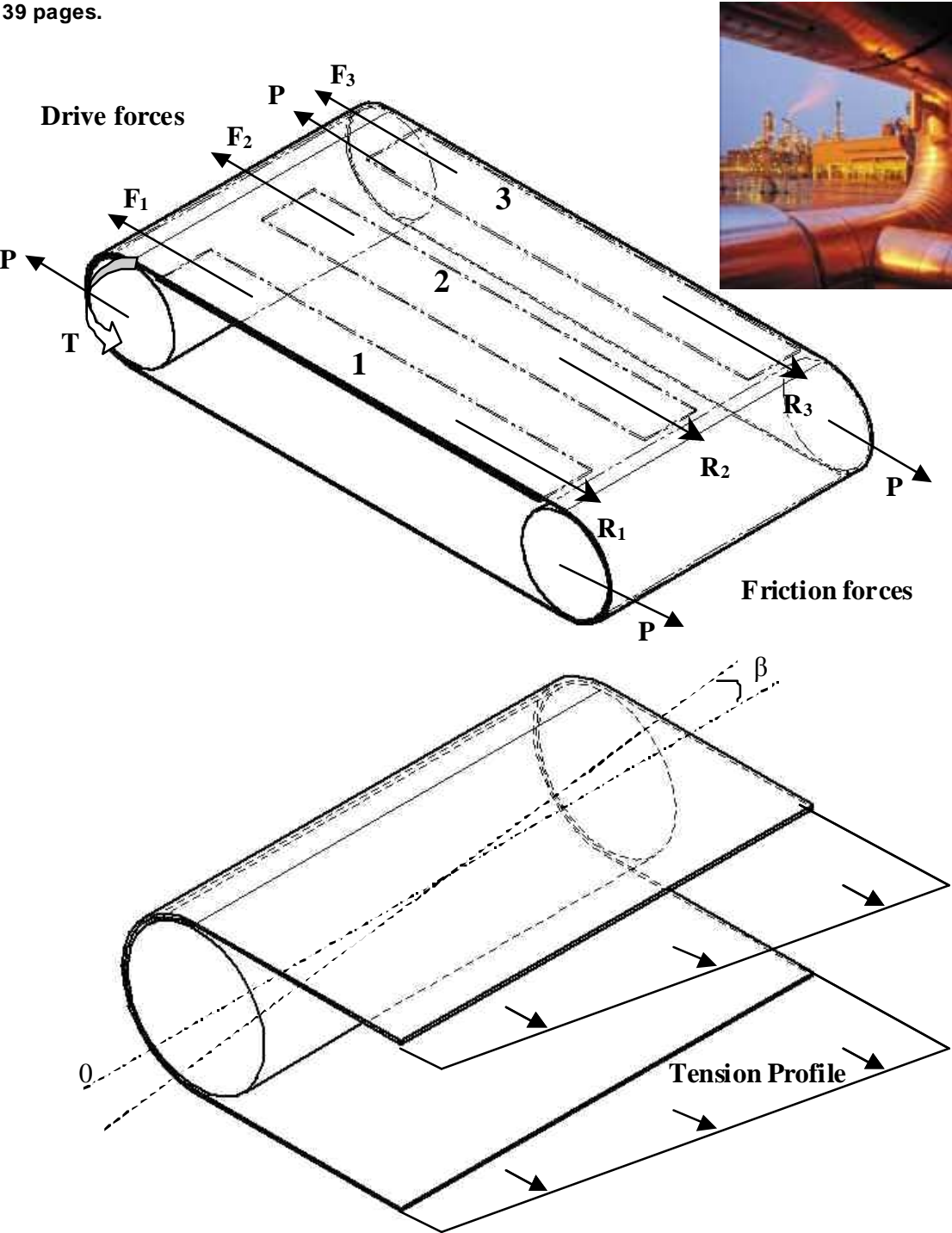



Low life of gas treatment fans

The Mozal Aluminium smelter's 52 Gas Treatment Centre main fans had a low life, which was thought to lie in the maintenance strategy applied. A full investigation into the root cause found that the problem lay in a haphazard approach to cause elimination, combined with improper modifications, a lack of follow-up on Condition Monitoring reports, and Alumina spillage due to a lack of production control. Report 23 pages.



Life Cycle optimisation project

The overhaul of primary mining equipment (Continuous Miners) at the Sasol Mining's Secunda Mines complex was presently on average performed after 1,75 million ton of operation. Such overhauls were performed by the OEM to the 'as new' condition at an estimated average cost of R8,0 million. A new machine is priced in the order of R 15,0 million. As the Condition Miner constitutes by far the highest proportion (35%) of underground mining cost, the question arised as to whether the present overhaul practice does not comprise a too high level of maintenance. A full life cycle costing study found significant evidence of the overhaul practice being completely in excess, with the possibility for saving in the order of R 60,0 million per annum. Report 34 pages.

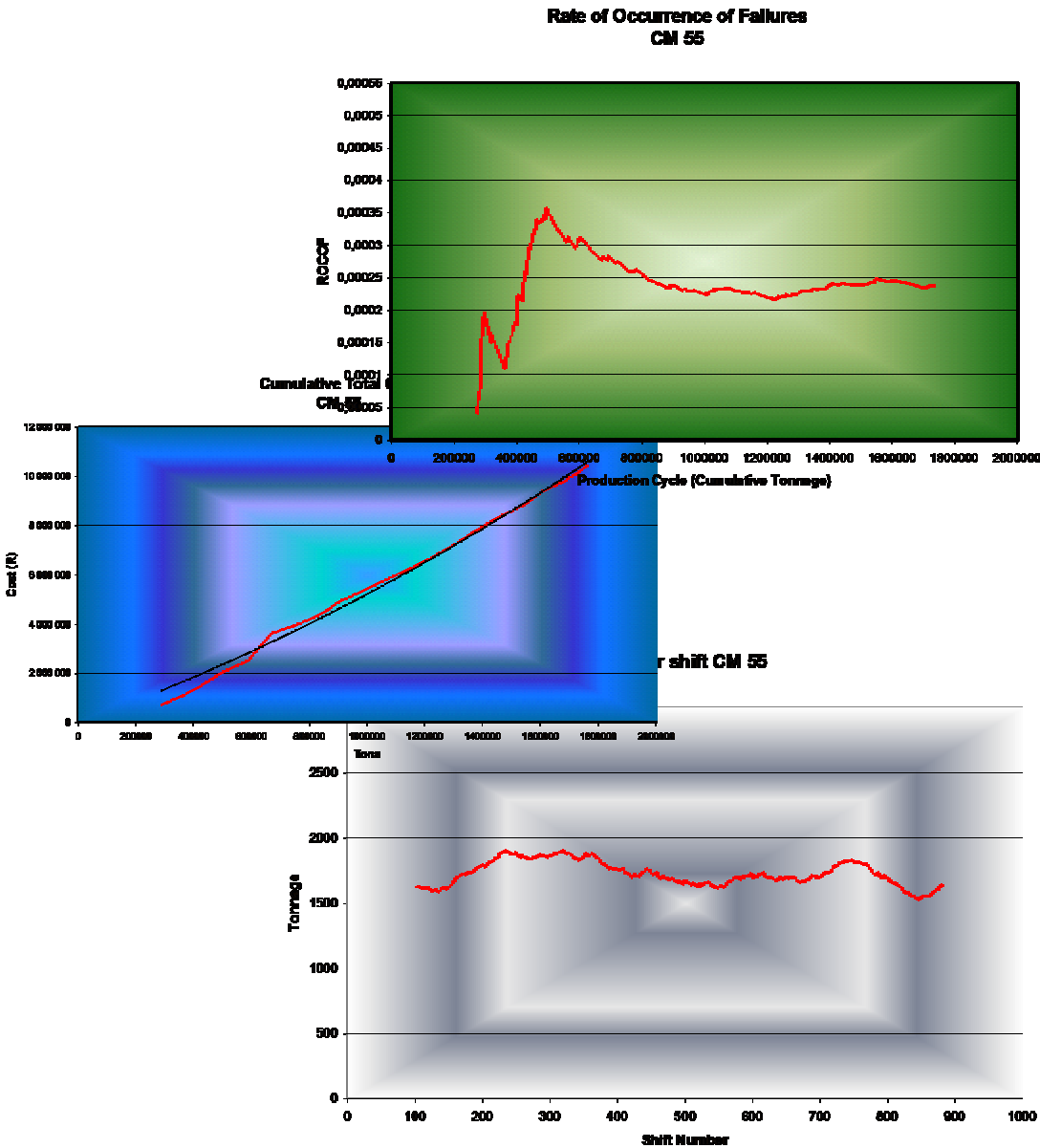

### Kiln catastrophic failure risk analysis

Alpha Cement's Lichtenburg plant's one cement kiln, which had a 30 year design life, was in its 24th year of operation (2001). It experienced problematic shell cracks since 1993. Moreover, during 2000 a crack of 11.3 meter across the circumference of the kiln shell resulted in a near-catastrophic failure. Due to the immense marginal loss, repair cost and safety risk associated with a catastrophic failure, a risk analysis was requested, to ascertain whether the kiln should be replaced before its planned replacement point. Based on extensive risk analysis in conjunction with the plant, it was recommended that the replacement of the kiln shell be done at the soonest possible time.

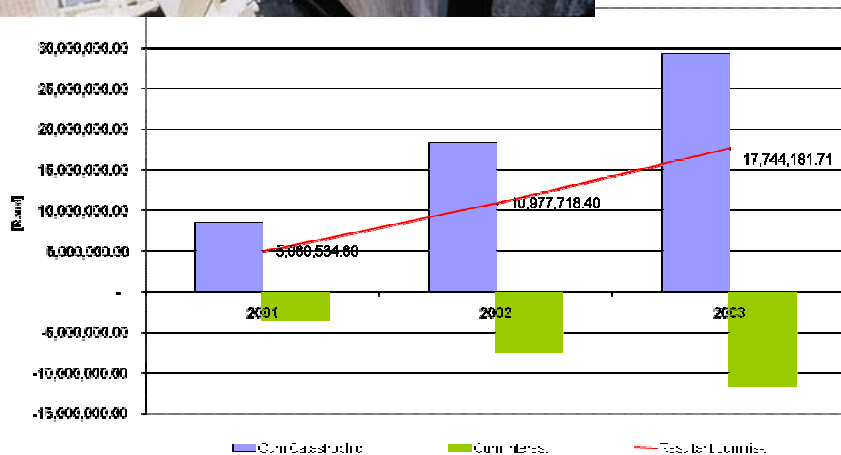
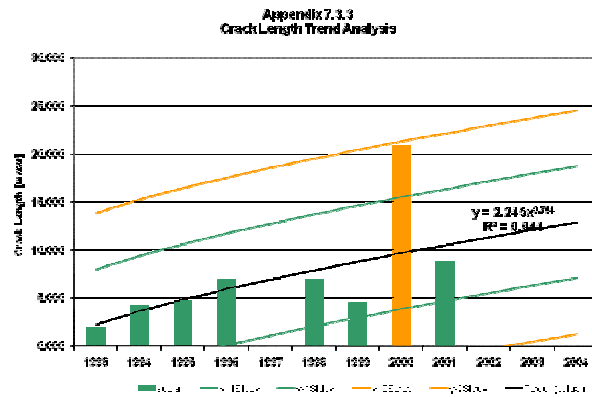



## Achievements

National Productivity Award 1982



This event was the eventual outcome of a young mine management team working hard and consistently over a period of three years to achieve a mine (the largest underground coal mine in the world at that stage) that broke production record upon production record, and was the top coal mine in the country regarding safety performance in spite of the mine having to produce a large proportion of its output with production machinery that was 40 years old.

## Curriculum Vitae: Dr Jasper L. Coetzee

### Member of the International Foundation for Research in Maintenance

IFRIM is a network of researchers with a core interest in promoting the science of maintenance and, more generally, engineered asset management.

The essence of IFRIM is a collection of individuals having a true academic approach to maintenance with core activities being:

- The promotion of fundamental and applied research in the areas of maintenance philosophy, technology, management theory, and application methodologies.
- The promotion of the development and ordering of scientific knowledge in the field of maintenance; and,
- The dissemination of knowledge.



First South African textbook in Maintenance - 1997

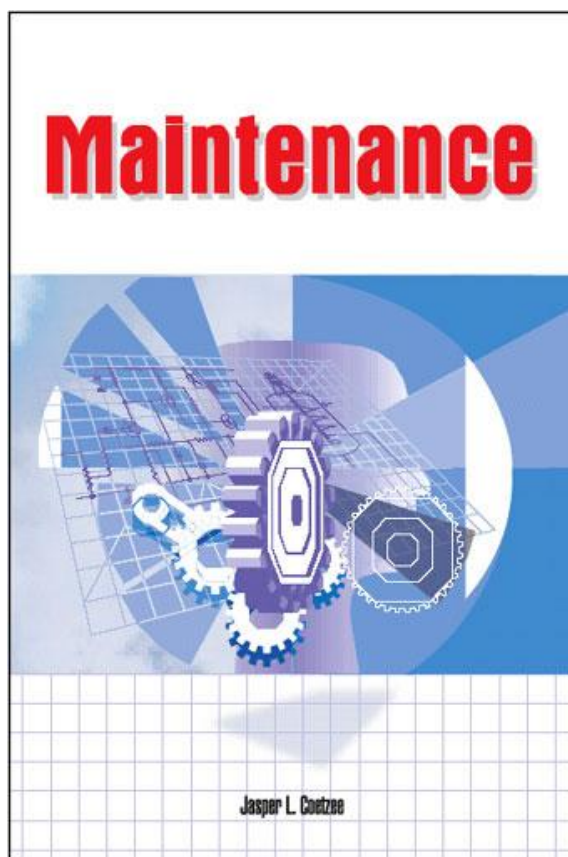

Failure is one of the unfortunate facts of life. Whenever man produces equipment or tools to increase his own productivity, he also has to deal with this unwanted side effect. And, although much effort is applied towards improving the reliability of machinery, the ever-increasing sophistication and complexity of these modern technological wonders gives rise to maintenance being one of the fastest growing industries in the world.

Maintenance is surely one of the oldest disciplines known to man. However, the maintenance subject area was until relatively recently thought of as being very basic, needing only the most basic knowledge. Most industrial organizations to some or other extent considered the maintenance department to be a necessary but costly luxury. This view of the maintenance function totally ignores the fact that a properly managed maintenance function creates and maintains high levels of availability, reliability and operability of plant. These high levels translate directly into production capacity, productive output and thus company profit.

In line with the relatively low importance attached to the maintenance function in most industrial organizations, the only educational requirements attached to the posts of maintenance engineers and managers was a degree or diploma in mechanical or electrical engineering. This is of course completely inadequate, as these leaders in one of the most cost intensive industries in the world need to be able to manage the process of failure properly. There is presently a very commendable worldwide drive to improve the education of maintenance personnel. This process is being led by a handful of maintenance academics from all parts of the world. Many of them (including the author) are members of the International Foundation for Research in Maintenance (IFRIM).

As a consequence of this newfound importance regarding the education of maintenance professionals, the theory of maintenance needs to be formalized, such that it can be presented in well-structured maintenance courses. The objective of this book is thus to provide a proper theoretical and practical foundation for the practice of maintenance in the typical industrial organization of our day. A number of such organizations have responded by providing each of their maintenance professionals with a copy of this book as reference work, while it is also used as prescribed work at a number of tertiary institutions as basis of their maintenance studies.

## Curriculum Vitae: Dr Jasper L. Coetzee

### South African Maintenance Association President's Award 2004



Citation:

SAMA President's Award, 2004: Jasper Coetzee

The individual President's award is given to persons who have advanced the cause of Asset Management in Southern Africa. (There is also an award for companies). In this year of 2004 the individual award is given to Dr Jasper L Coetzee, a consultant in maintenance engineering and management for the past 30 years. Dr Coetzee has both a practical and academic approach to the subject, having worked as a maintenance engineer and having lectured on the subject at various universities. He continues this activity by the provision of courses in maintenance to all levels of the Southern African maintenance community, through his consultancy, set up in 1987.

He is one of the few people in South Africa to have published a book on maintenance, entitled, simply, Maintenance. More specifically, he is one of the few authors in the world who has taken the ground-breaking work of Harry Asher of the USA in the reliability of maintained systems, and explained it and clarified it so that it becomes useful to the average maintenance practitioner.

He is also a member of the board of advisors of IFRIM, the International Foundation for Research in Maintenance.

He started his career as a millwright and now has a doctorate in engineering. He is therefore a rare man, a man who can work with his hands and work with his head. I ask Jasper to come up now and receive his award from our President.

E A Bradley

SAMA Council, 2004



## **Publications & Papers**

**Coetzee, J.L., Computerisation gives control of a complex situation, Mining World volume 2 no.10, November 1983, pp 87 - 95.**

**Coetzee, J.L., Benefits and pains of computerised maintenance management, Maintenance Management Convention, South African Institution of Mechanical Engineers, pp B2.1 - B2.20, 1986.**

**Coetzee, J.L., Die struktuur van Instandhouding, Suid-Afrikaanse Akademie vir Wetenskap en Kuns, Vaaldriehoek-Werkgemeenskap, 1988.**

**Coetzee, J.L., The effective use of Maintenance Information, Maintenance Forum 1990, Vanderbijlpark, 1990.**

**Coetzee, J.L., Maintenance Systems as a means towards higher productivity, Maintenance Forum 1991, Kempton Park, 1991.**

**Coetzee, J.L., Gouws, J., Maintenance Audits as a means to improving Maintenance Quality, Maintenance Forum 1992, Sandton, 1992.**

**Coetzee, Jasper L., Die analise van falingsdata met 'n langtermyn tendens", Masters Dissertation (94 pp), 1995.**

**Coetzee, J.L., Maintenance strategy setting – a dangerous affair, Maintenance in mining conference, Johannesburg, 1996/1.**

**Coetzee, J.L., Measuring maintenance performance, Annual Maintenance Convention, Johannesburg, 1996/2.**

**Coetzee, J.L., Reliability Degradation and the Equipment Replacement Problem, ICOMS 96, Melbourne, Australia, 1996/3.**

**Coetzee, J.L., The role of NHPP models in the practical analysis of maintenance failure data, Reliability Engineering and System Safety 56, 1997/1.**

**Coetzee, J.L., Towards a general maintenance model, IFRIM workshop, Hong Kong, 1997/2.**

**Coetzee, J.L., A structured approach to Maintenance Auditing, ICOMS 98, Adelaide, Australia, 1998.**

**Coetzee, J.L., A holistic approach to the maintenance "problem", Journal of Quality in Maintenance Engineering, Vol 5 No 3, 1999.**

**Coetzee, J.L., Reducing Maintenance Risk – a macro perspective, I.M.E. Maintenance Conference, 2000/1.**

**Coetzee, J.L., Maintenance success using a holistic approach, Maintenex Conference, 2000/2.**

**Coetzee, J.L., The Maintenance Strategy Gap, World Trends in Maintenance Conference 2000, 2000/3.**

## Curriculum Vitae: Dr Jasper L. Coetzee

Vlok, P.J., Coetzee, J.L., Advances in Renewal Decision Making utilising the Proportional Hazards Model with Vibration Covariates, South African Journal of Industrial Engineering, Vol 11 No 1, 2000/4.

Coetzee, J.L., Selecting Failure Management Policies, Reliability Centred Maintenance Conference 2001, Marcus Evans, 2001/1.

Coetzee, J.L., The rationale behind Outsourcing of Maintenance - why it cannot be avoided, World Trends in Maintenance Conference 2001, 2001/2.

Coetzee, J.L., What are we doing to our people?, World Trends in Maintenance Conference 2001, 2001/3.

Coetzee, J.L., The new Maintenance Management Paradigm, World Trends in Maintenance Conference 2001, 2001/4.

Coetzee, Jasper L., An optimised instrument for designing a maintenance plan – a sequel to Reliability Centred Maintenance, Doctoral Thesis (225 pp), 2001/5.

Vlok, P.J., Coetzee, J.L., Banjevic, D., Jardine, A.K.S., Makis, V., Optimal component replacement decisions using Vibration Monitoring and the Proportional Hazards model, Journal of the Operational Research Society, vol. 53 no. 2, February 2002, 2002/1.

Coetzee, J.L., New advances in Reliability Centred Maintenance, IFRIMmm Conference, Växjö, Sweden, 6-8 May 2002, 2002/2.

Coetzee, J.L., Developments in Reliability Centred Maintenance for the new millennium, ICOMS 2002, Brisbane, Australia, 2002/3.

Kotze, R., Coetzee, J.L., Getting your money's worth from your people, ICOMS 2002, Brisbane, Australia, 2002/4.

Coetzee, J.L., Achieving Maintenance Excellence through Total Strategic Management, TECSUP 2002, Lima, Peru, 2002/5.

Coetzee, J.L., Claasen, S.J., Reliability Centred Maintenance for industrial use: Significant advances for the new millennium, South African Journal of Industrial Engineering, Vol 13 No 2, 2002/6.

Coetzee, J.L., Achieving Maintenance Excellence through Total Strategic Management, SAMA Newsletter, 2004/1.

Coetzee, J.L., What analysis for which machine or part?, ICAMM 2004, CSIR Conference Centre, Pretoria, 2004/2.

Coetzee, J.L., Understanding the maintenance organisation – the role of maintenance management models, Unpublished Article, 2005/1.

Coetzee, J.L., Maintenance Strategic Management - a prerequisite for business survival, IMEC 2005, Toronto, Canada, 2005/2.

Coetzee, J.L., Stepped approach towards achieving Maintenance Excellence through Strategic Management, IMEC 2005, Toronto, Canada, 2005/3.

Coetzee, J.L., The strategic role of leadership for maintenance executives, People Management for Maintenance Excellence Conference, Melbourne, Australia, 2006/1.

## Curriculum Vitae: Dr Jasper L. Coetzee

Coetzee, J.L., Management Skills for Maintenance Professionals, People Management for Maintenance Excellence Conference, Melbourne, Australia, 2006/2.

Van der Walt, N., Coetzee, J.L., Die Afrikaner — sy toekoms as leier in 'n transformerende gemeenskap, S.A. Akademie vir Wetenskap en Kuns Jaarvergadering, Bloemfontein, 2006/3.

Coetzee, J.L., Setting the standard for excellence in mining maintenance, GEMMS 2006, Johannesburg. 2006/4.

Hodkiewicz, M.R., Coetzee, J.L., Dwight, R.A., Sharp, J.M., The Importance of Knowledge Management to the Asset Management Process, Oil and Gas Review, December 2006, 2006/5.

Coetzee, J.L., Reliability Centered Maintenance: a prerequisite for proactiveness in maintenance, IPAMC 2007, Tehran, Iran, 2007/1.

Coetzee, J.L., Using Renewal Theory to maximum effect specifying use based maintenance tasks in RCM, IPAMC 2007, Tehran, Iran, 2007/2.

Coetzee, J.L., Eradicating failure through creative thinking, IPAMC 2007, Tehran, Iran, 2007/3.

Coetzee, J.L., Die Suid-Afrikaanse tegnologiebasis in krisis, S.A. Akademie vir Wetenskap en Kuns Jaarvergadering, Stellenbosch, 2008/1.

Coetzee, J.L., Poor maintenance poses a risk for the Systems Engineering industry, INCOSE 2008, Pretoria, 2008/2.

Coetzee, J.L., Achieving motivated maintainers and maintenance technicians in the workplace, IPAMC 2008, Tehran, Iran, 2008/3.

Coetzee, J.L., Achieving the maximum benefit from maintenance contracting, IPAMC 2008, Tehran, Iran, 2008/4.

Coetzee, J.L., The relationship between Maintenance Engineering and Industrial Engineering, SAIE Conference, Magaliesburg, 2008/5.

Coetzee, J.L., Achieving motivated maintainers and maintenance technicians in the workplace, PRPMF, Johannesburg, 2009.

Coetzee, J.L., Maintenance planning and scheduling, Aryana workshop, Tehran, Iran, 2010/1.

Coetzee, J.L., Developing Maintenance tactics, Aryana workshop, Tehran, Iran, 2010/2.

Coetzee, J.L., Maintenance Human Resource Management, Aryana workshop, Tehran, Iran, 2010/3.

Coetzee, J.L., Breymann, W., Financial Maintenance modelling in the framework of the Unified Financial Analysis methodology, SAIE Conference, Mulderdrift, 2010/4.